

INTRODUCTION TO MICROSTRIP ANTENNA

ECE 516E – ANTENNA & RADIOWAVE PROPAGATION

Monday, January 12, 2026

WHAT IS A MICROSTRIP ANTENNA?

1. **Microstrip antenna (also called Patch antenna)** is an antenna fabricated using photolithographic techniques on a Printed Circuit Board (PCB).
2. It consists of a very thin metallic strip placed on a ground plane with a dielectric material in-between.

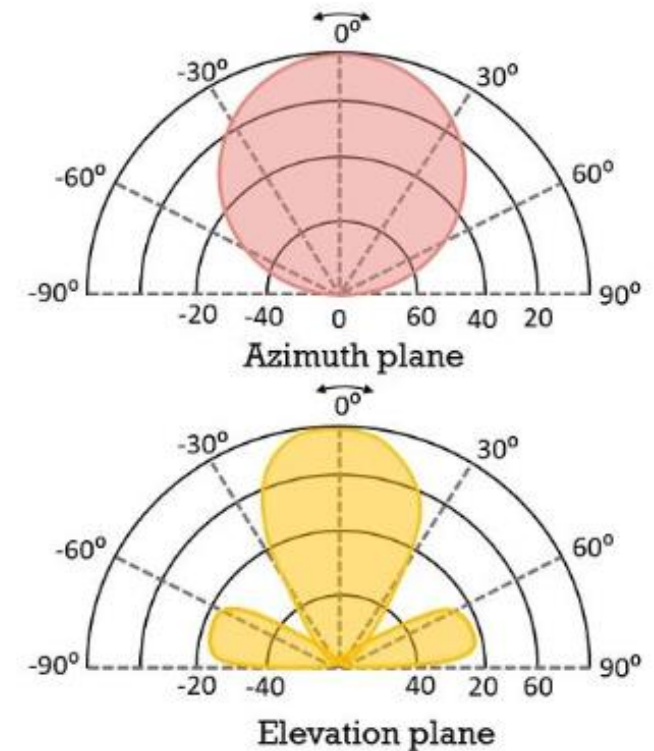
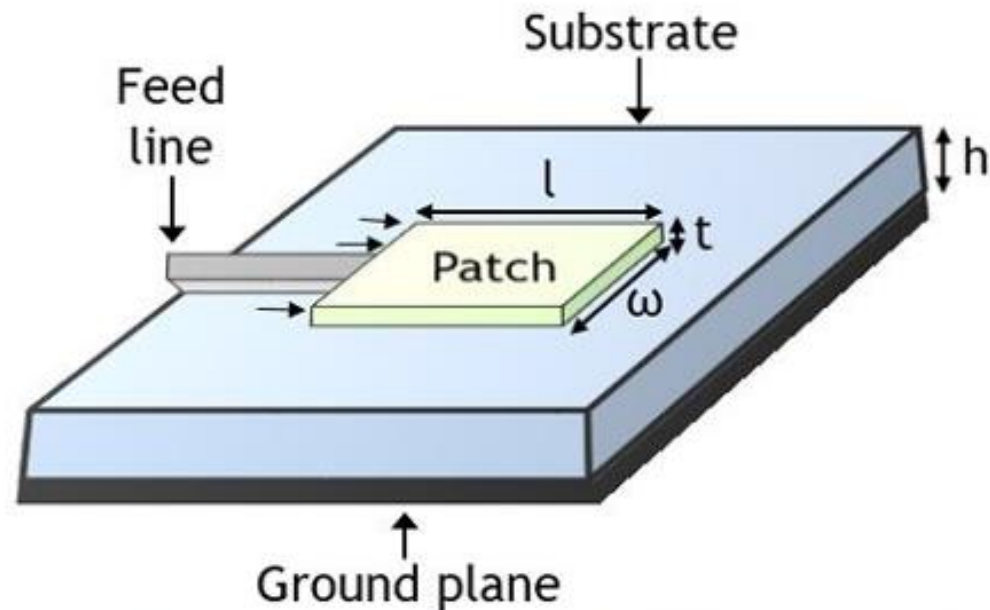

(a) Radiation pattern of Microstrip Antenna

OVERVIEW OF MICROSTRIP ANTENNAS

1. Microstrip antenna is one of the most used antennas at microwave frequencies ($f > 1$ GHz) (2GHz-5GHz - WiFi, Bluetooth, Zigbee, ect).
2. It usually consists of a metal “patch” on top of a grounded dielectric substrate.
3. The patch may be in a variety of shapes, but rectangular and circular are the most common.

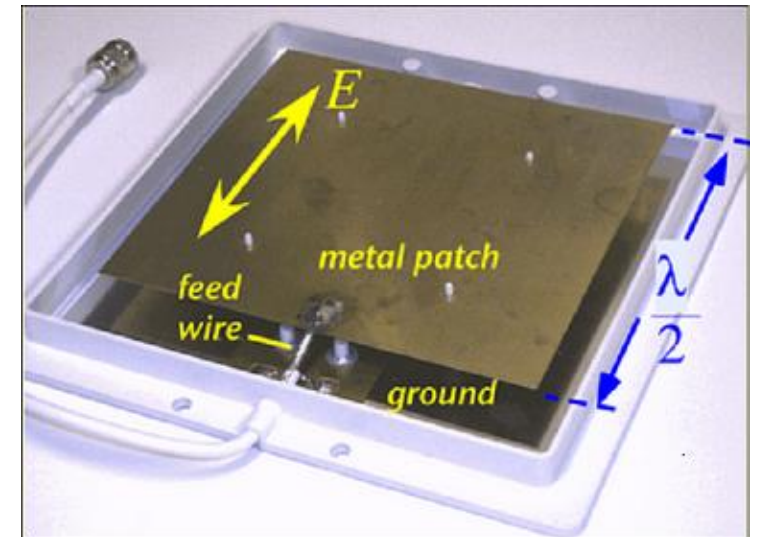
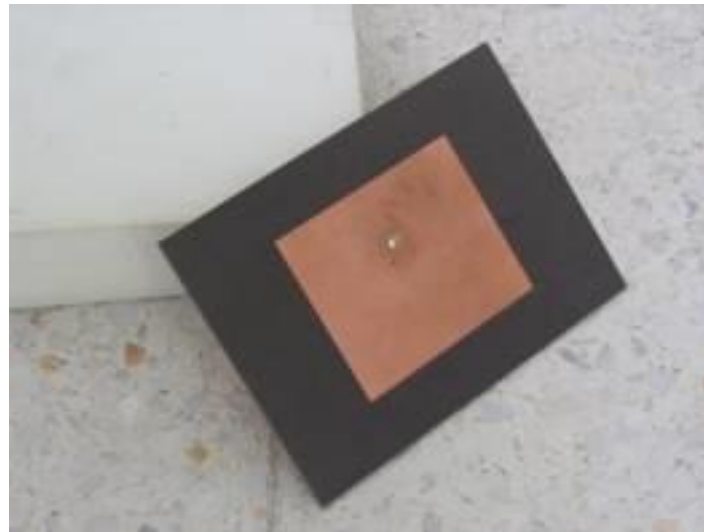
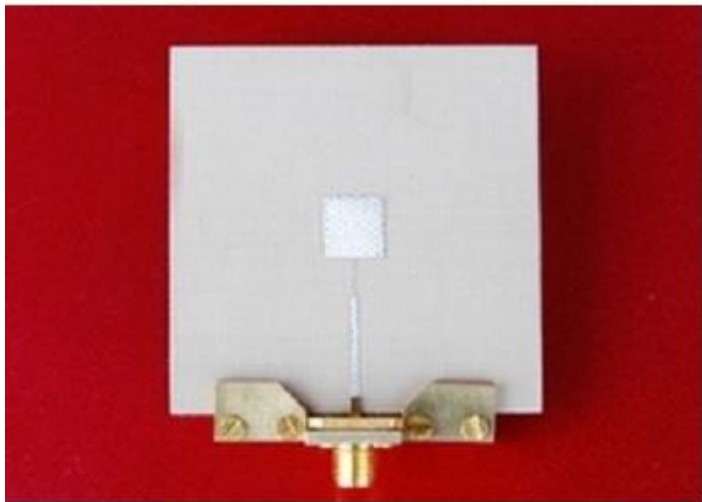

OVERVIEW OF MICROSTRIP ANTENNAS

Common Shapes

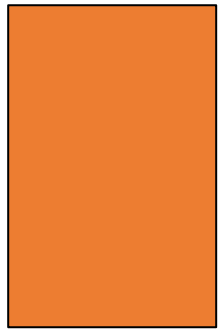

Rectangular

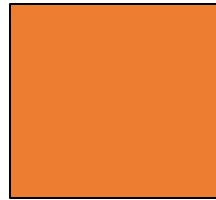

Square

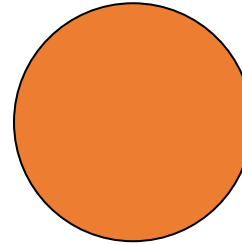

Circular

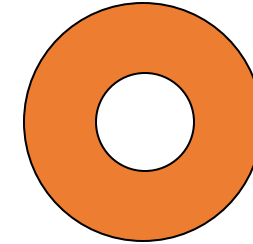

Annular ring

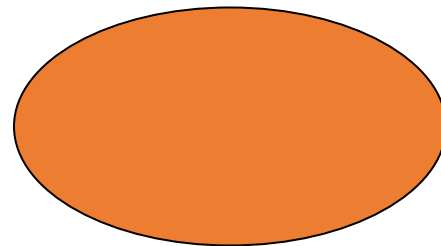

Elliptical

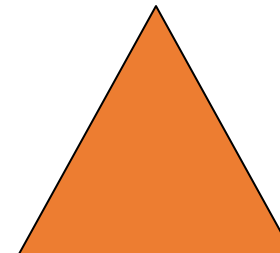

Triangular

Take a closer look at the GSM Patch Antenna in the Laboratory

BRIEF HISTORY OF MICROSTRIP ANTENNAS

1. Invented by Bob Munson in 1972 (but earlier work by Dechamps goes back to 1953).
2. Became popular starting in the 1970s.

Related Publications:

1. G. Deschamps and W. Sichak, "Microstrip Microwave Antennas," *Proc. of Third Symp. on USAF Antenna Research and Development Program*, October 18–22, 1953.
2. R. E. Munson, "Microstrip Phased Array Antennas," *Proc. of Twenty-Second Symp. on USAF Antenna Research and Development Program*, October 1972.
3. R. E. Munson, "Conformal Microstrip Antennas and Microstrip Phased Arrays," *IEEE Trans. Antennas Propagat.*, vol. AP-22, no. 1 (January 1974): 74–78.

ADVANTAGES OF MICROSTRIP ANTENNAS

Microstrip antennas have many advantages, including:

1. **Cost:** Microstrip antennas are inexpensive to design and manufacture.
2. **Weight:** They are lightweight.
3. **Size:** They are low volume and have a low profile.
4. **Shape:** They can conform to planar and non-planar surfaces.
5. **Compatibility:** They are compatible with monolithic and hybrid microwave integrated circuits.
6. **Bandwidth:** Their design bandwidth can be expanded by increasing the thickness of the dielectric material.
7. **Polarization:** They can provide linear and circular polarization.
8. **Wide Frequency:** They can operate at dual and triple frequencies.
9. **Gain:** Patch arrays can provide high gains at a low additional cost.
10. **Ease of use:** They are easy to fabricate, modify, and customize.
11. **Mechanical robustness:** They are mechanically robust

DISADVANTAGES OF MICROSTRIP ANTENNAS

1. **Low bandwidth** (but can be improved by a variety of techniques). Bandwidths of a few percent are typical. Bandwidth is:
 1. proportional to the substrate thickness, and
 2. inversely proportional to the substrate permittivity.
2. Efficiency may be lower than with other antennas. Efficiency is limited by conductor and dielectric losses, and by surface-wave loss.
3. Only used at microwave frequencies and above (the substrate becomes too large at lower frequencies).
4. Cannot handle extremely large amounts of power due to dielectric breakdown.

ANTENNA EFFICIENCY

- 1. Antenna efficiency** is a measure of how well an antenna converts radio-frequency power into radiated power. It can also refer to how well an antenna converts electromagnetic waves into electric signals (Reciprocity).

$$\text{Antenna Efficiency} = \frac{P_{\text{radiated}}}{P_T}$$

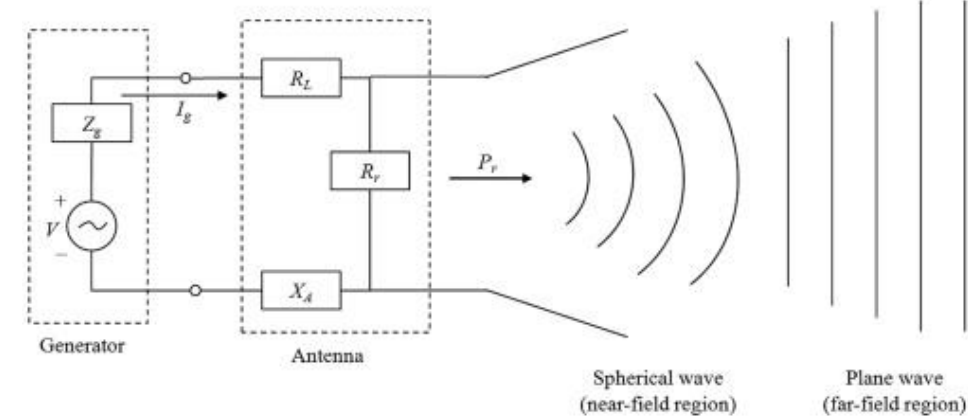

- 1. Antenna efficiency** can be stated in two ways:
 - a) Radiation efficiency:** The ratio of the power radiated by an antenna to the power fed to it. This is also known as the antenna's ability to convert radio-frequency power into radiated power.
 - b) Energy projection/Directivity:** The ratio of the energy projected to a target area to the total energy of radio waves. This measures how effectively the energy is utilized.

OVERVIEW OF MICROSTRIP ANTENNAS - ARRAYS

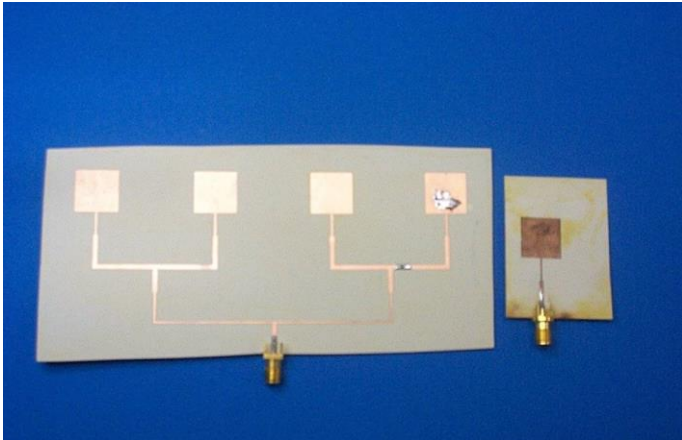

Linear array (1-D corporate feed)

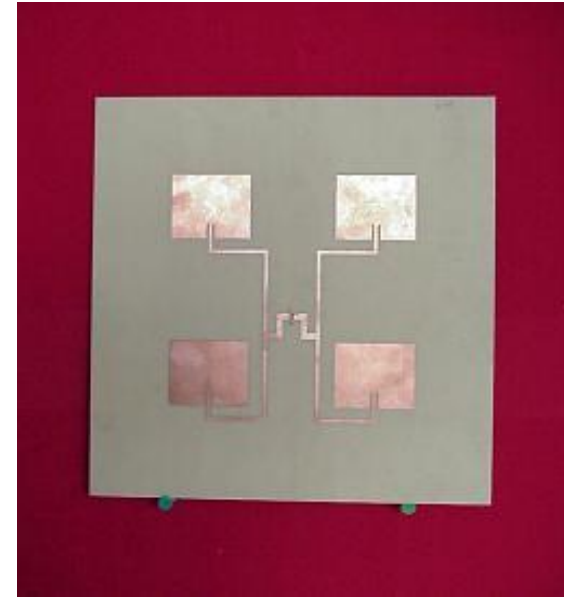

2x2 array

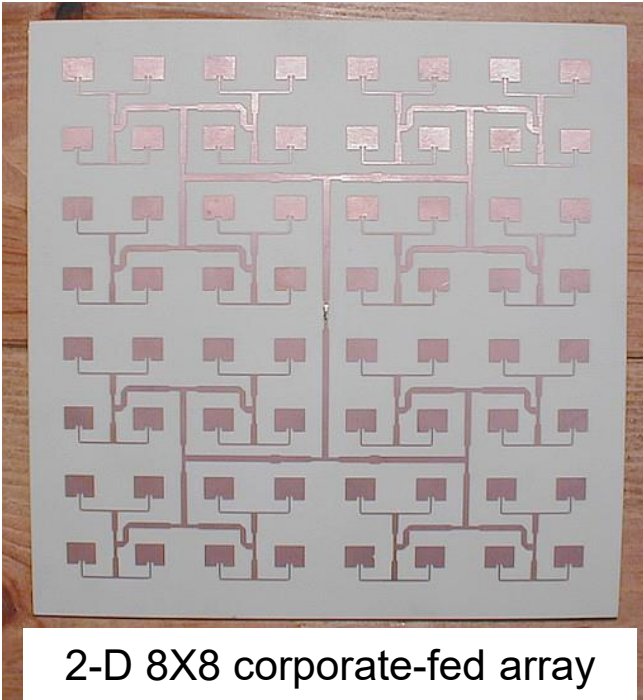

2-D 8X8 corporate-fed array

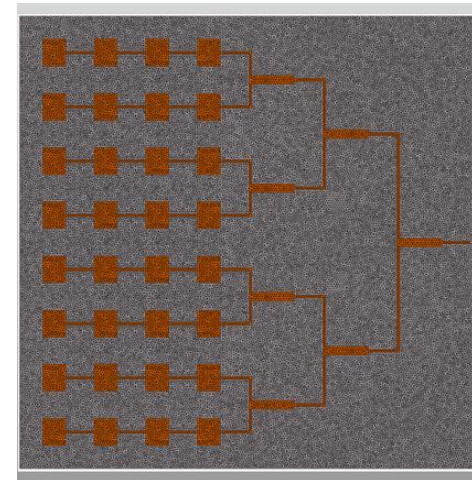

4 x 8 corporate-fed / series-fed array

RECTANGULAR PATCH

Note:

The fields and current are approximately independent of y for the dominant (1,0) mode.

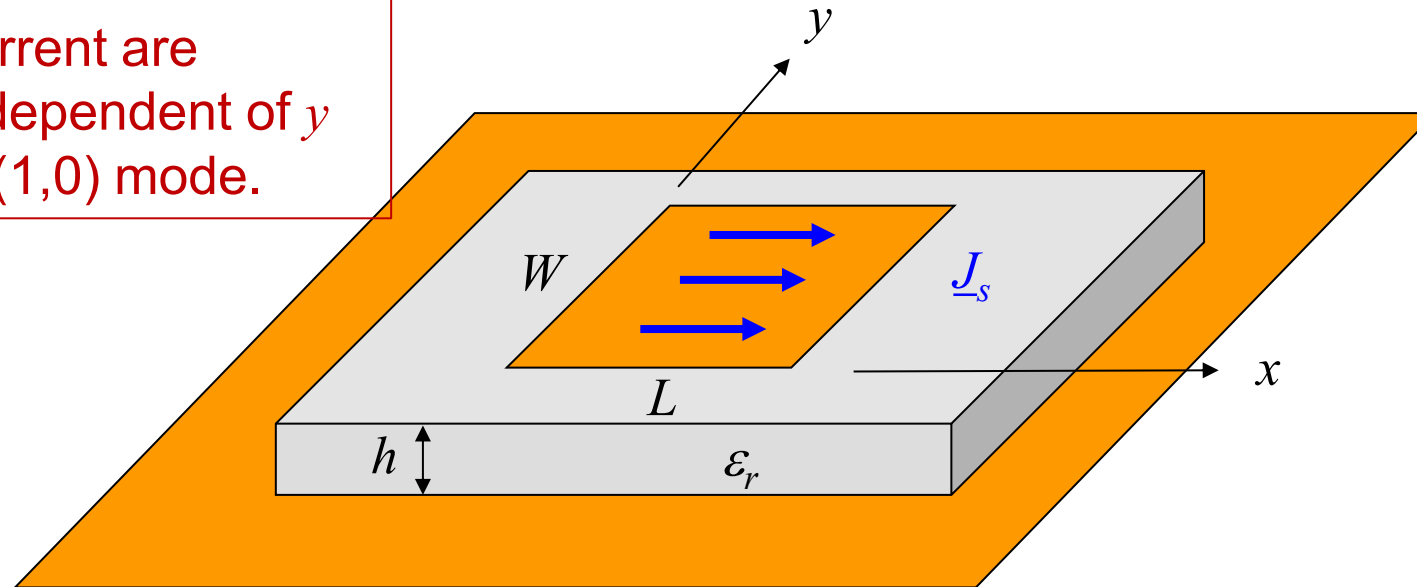

Note:

- L is the resonant dimension (direction of current flow).
- The width W is usually chosen to be larger than L (to get higher bandwidth). However, usually $W < 2L$ (to avoid problems with the (0,2) mode).

$W = 1.5L$ is typical.

CIRCULAR PATCH

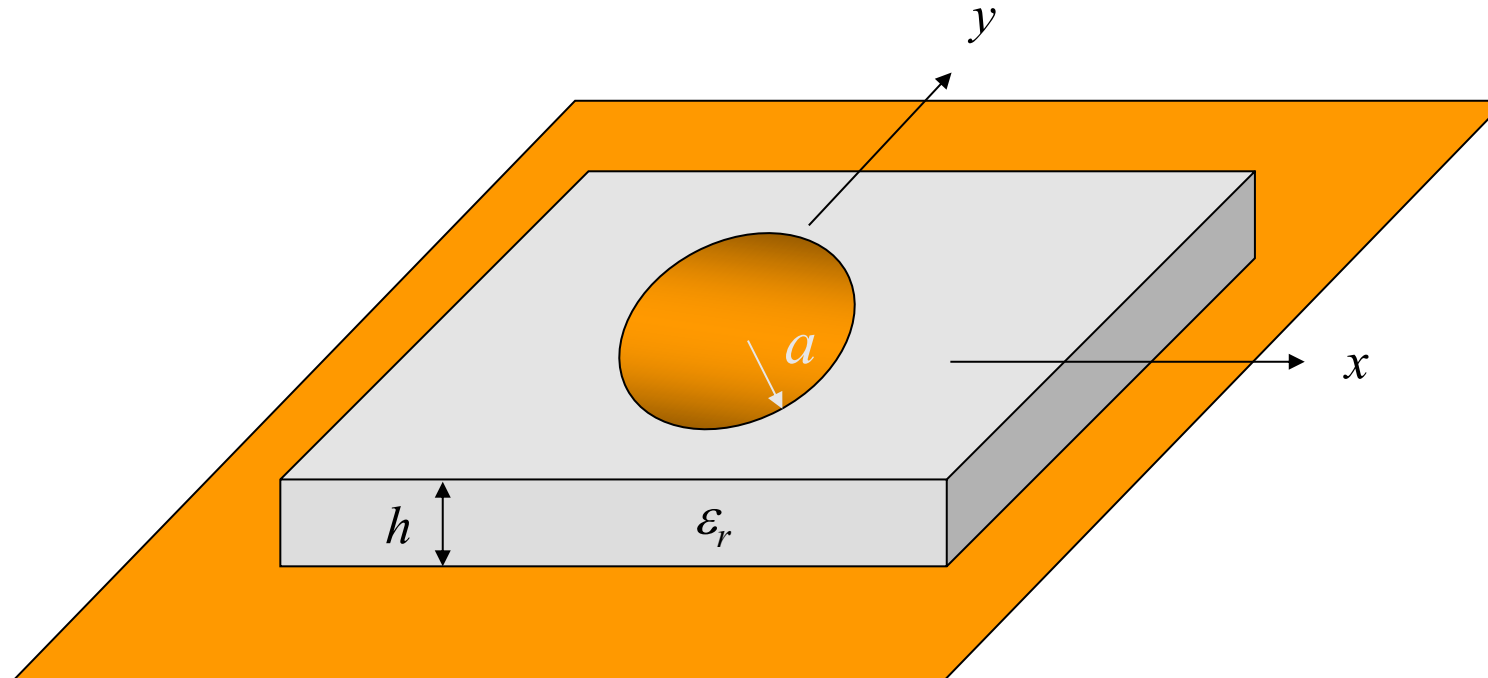

The location of the feed determines the direction of current flow and hence the polarization of the radiated field.

COAXIAL FEED /01

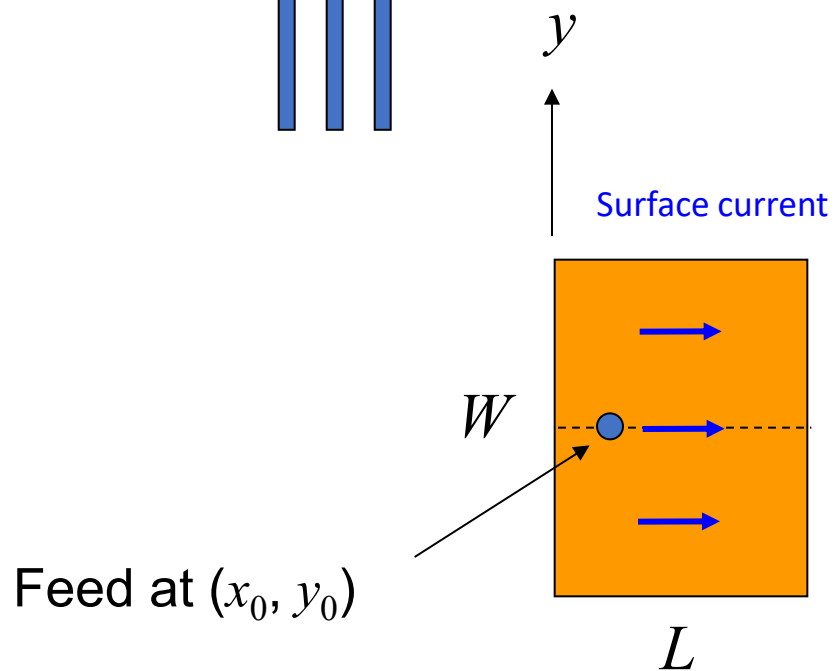
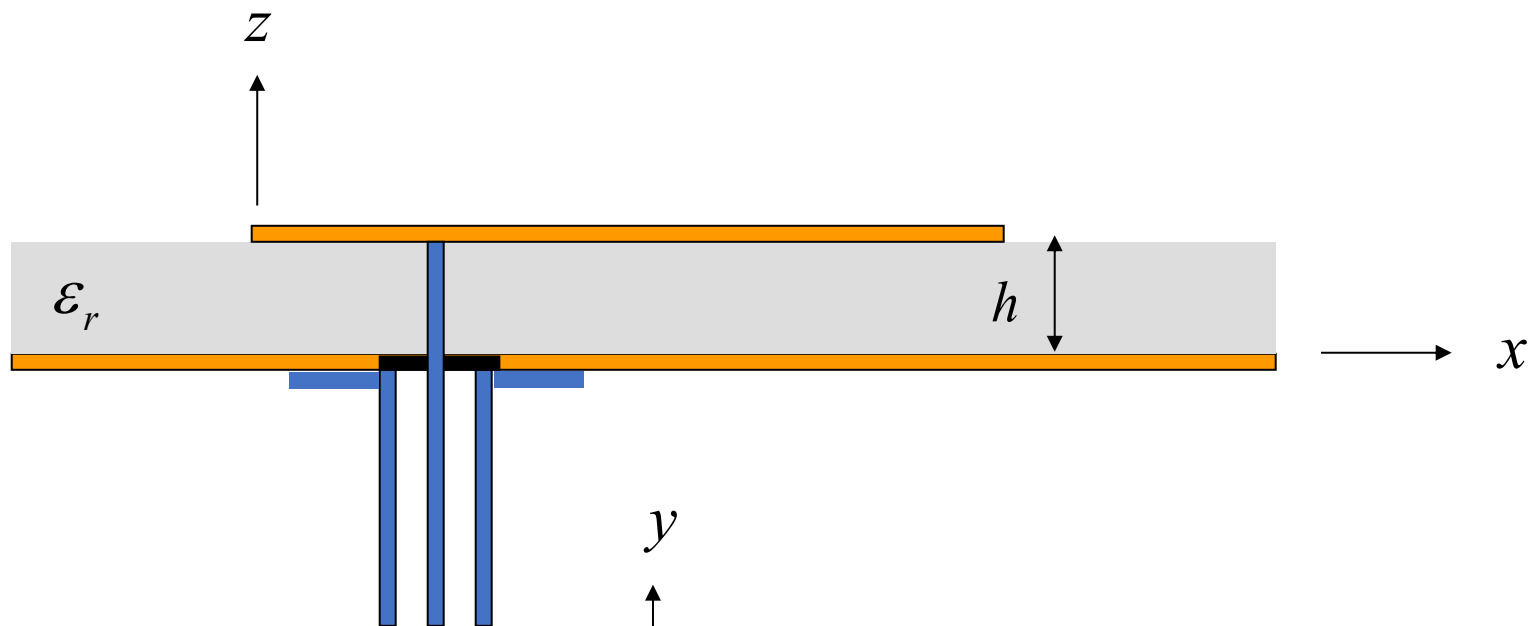

Note:

- A feed along the centerline at $y = W/2$ is the most common.
- This minimizes higher-order modes and cross-pol).

COAXIAL FEED /02

Advantages:

- Simple
- Directly compatible with coaxial cables
- Easy to obtain input match by adjusting feed position

Disadvantages:

- Significant probe (feed) radiation for thicker substrates
- Significant probe inductance for thicker substrates (limits bandwidth)
- Not easily compatible with arrays

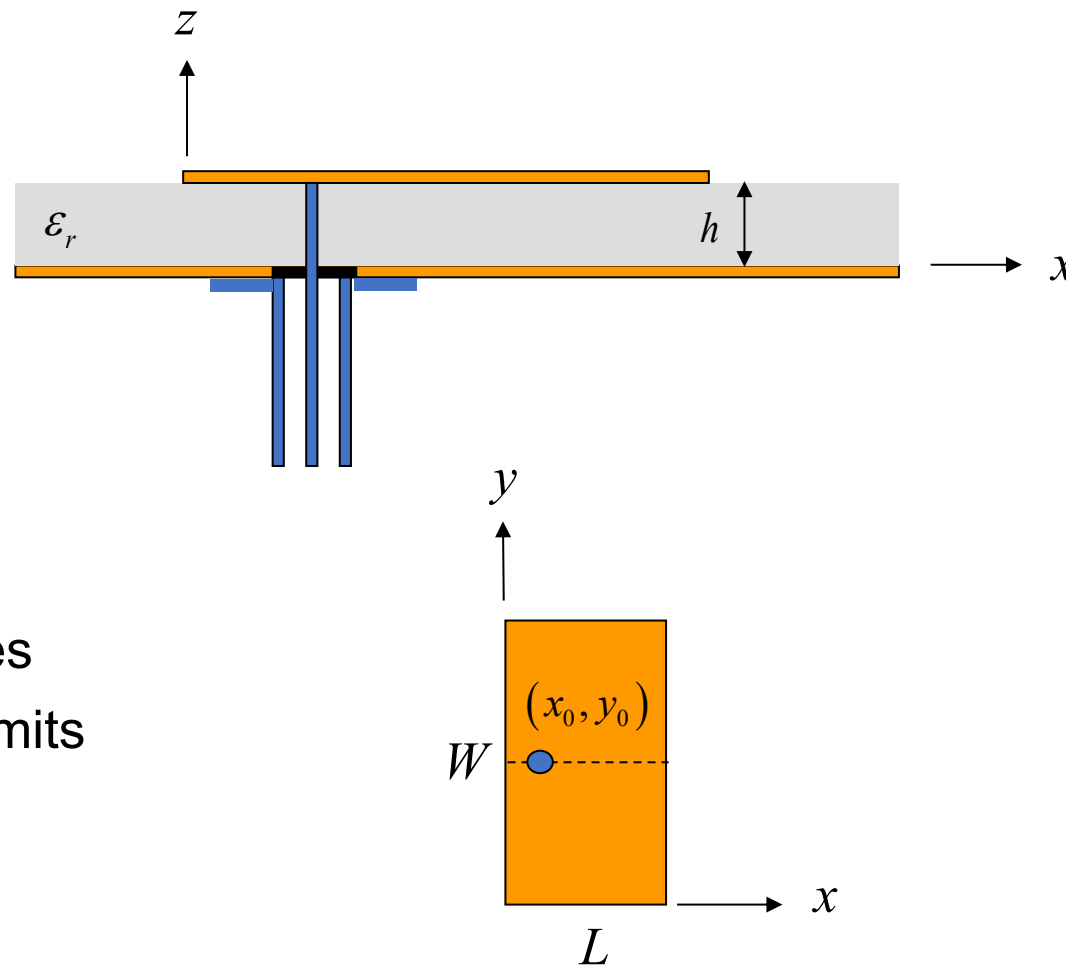

INSET FEED /01

Advantages:

- Simple
- Allows for planar feeding
- Easy to use with arrays
- Easy to obtain input match

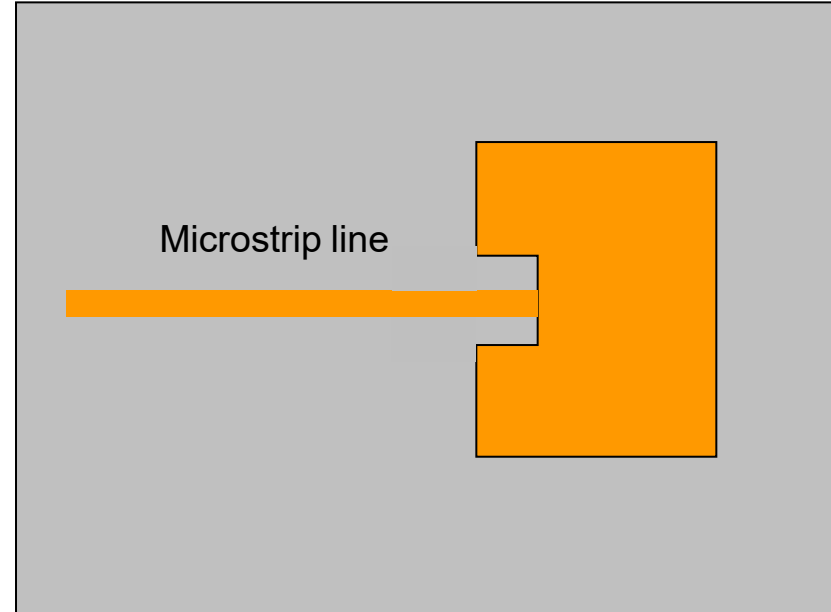

Disadvantages:

- Significant line radiation for thicker substrates
- For deep notches, patch current and radiation pattern may show distortion

INSET FEED /02

An investigation has shown that the resonant input resistance varies as:

$$R_{in} = A \cos^2 \left(\frac{\pi}{2} \left(\frac{2x_0}{L} - B \right) \right)$$

Less accurate approximation:

$$R \approx R_{edge} \cos^2 \left(\frac{\pi x_0}{L} \right)$$

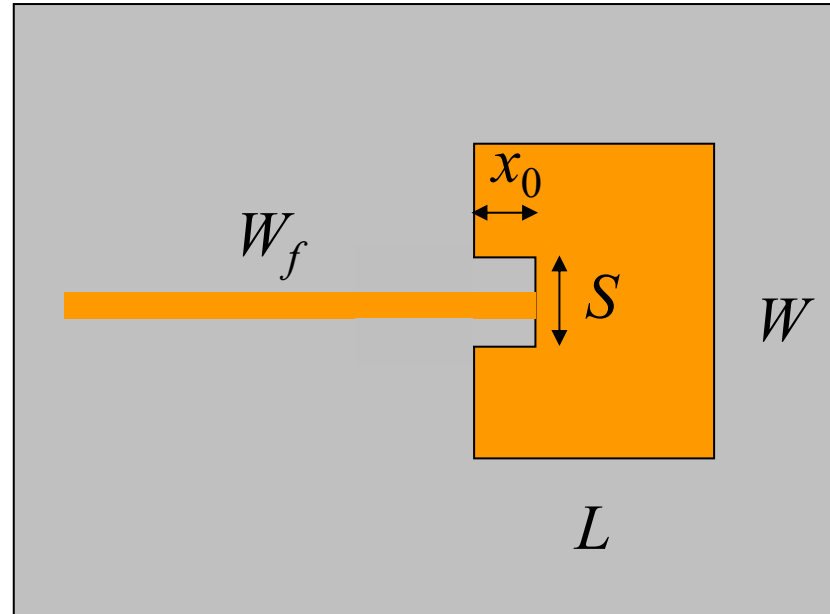

The coefficients A and B depend on the notch width S but (to a good approximation) not on the line width W_f .

Y. Hu, D. R. Jackson, J. T. Williams, and S. A. Long, "Characterization of the Input Impedance of the Inset-Fed Rectangular Microstrip Antenna," *IEEE Trans. Antennas and Propagation*, Vol. 56, No. 10, pp. 3314-3318, Oct. 2008.

PROXIMITY COUPLED FEED

(Electromagnetically-coupled Feed)

Advantages:

- Allows for planar feeding
- Less line radiation compared to microstrip feed (the line is closer to the ground plane)
- Can allow for higher bandwidth (no probe inductance, so substrate can be thicker)

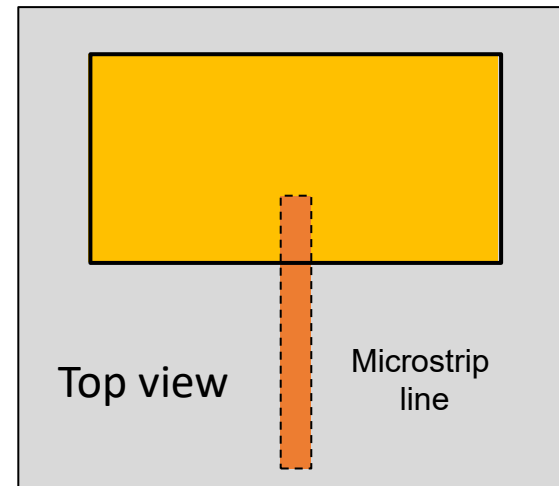
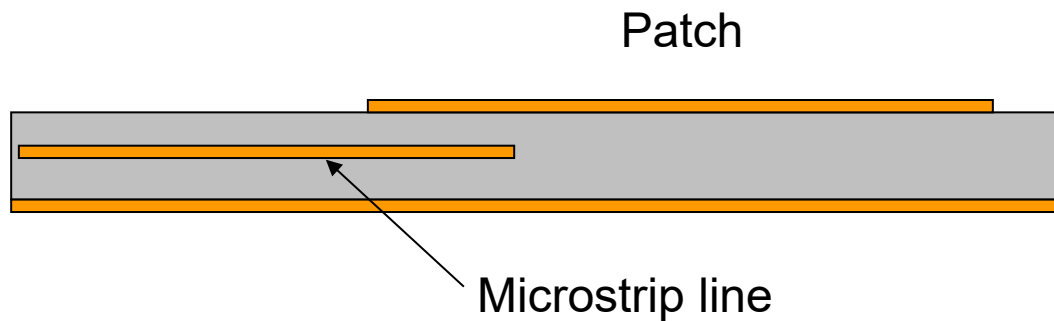

Disadvantages:

- Requires multilayer fabrication
- Alignment is important for input match

GAP-COUPLED FEED

Gap-coupled Feed

Advantages:

- Allows for planar feeding
- Can allow for a match even with high edge impedances, where a notch might be too large (e.g., when using a high permittivity substrate)

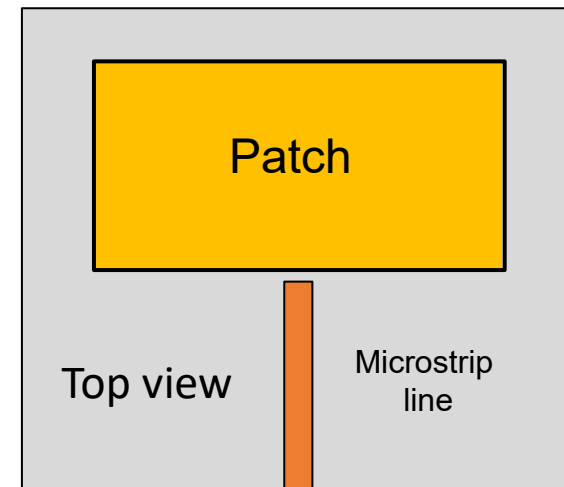
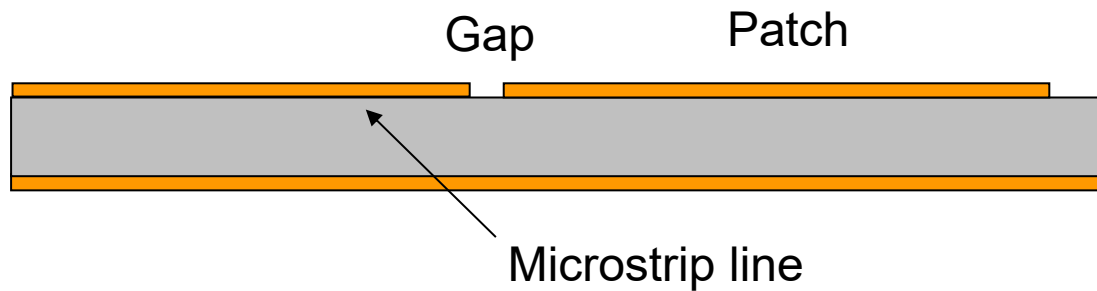

Disadvantages:

- Requires accurate gap fabrication
- Requires full-wave design

APERTURE-COUPLED FEED

Aperture-coupled Patch (ACP)

Advantages:

- Allows for planar feeding
- Feed-line radiation is isolated from patch radiation
- Higher bandwidth is possible since probe inductance is eliminated (allowing for a thick substrate), and also a double-resonance can be created
- Allows for use of different substrates to optimize antenna and feed-circuit performance

Disadvantages:

- Requires multilayer fabrication
- Alignment is important for input match

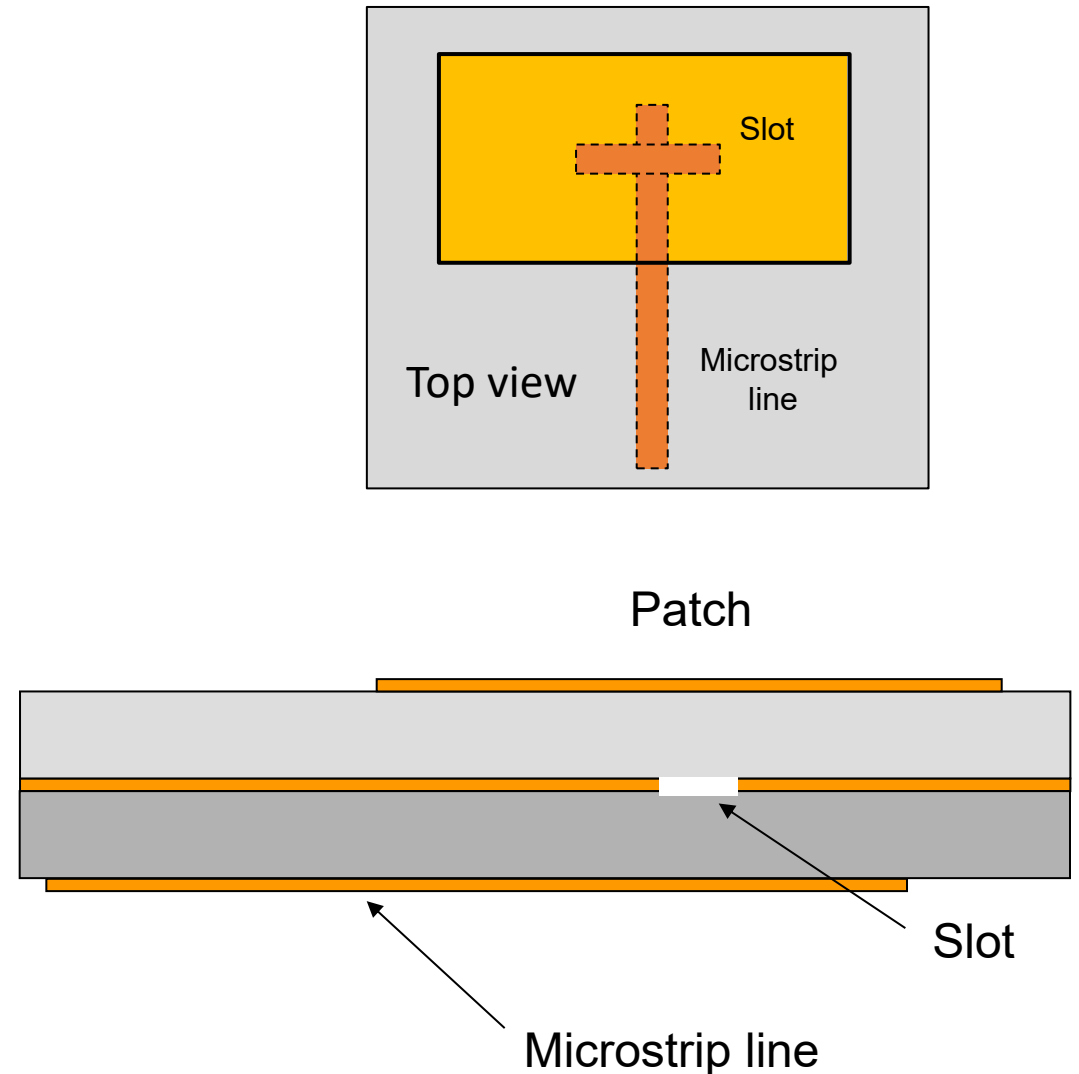

BASIC PRINCIPLES OF OPERATION

Key features:

- The patch acts approximately as a resonant cavity (with perfect electric conductor (PEC) walls on top and bottom, and perfect magnetic conductor (PMC) walls on the edges).
- Radiation is accounted for by using an effective loss tangent for the substrate.
- In a cavity, only **certain modes are allowed to exist**, at different resonance frequencies.
- If the antenna is excited at a **resonance frequency**, a **strong field is set up inside the cavity**, and a strong current on the (bottom) surface of the patch. This produces significant radiation (a good antenna).



- As the substrate gets thinner the patch current radiates less, due to image cancellation (current and image are separated by $2h$).
- However, the Q of the resonant cavity mode also increases, making the patch currents stronger at resonance.
- These two effects cancel, allowing the patch to radiate well even for thin substrates (though the bandwidth decreases).

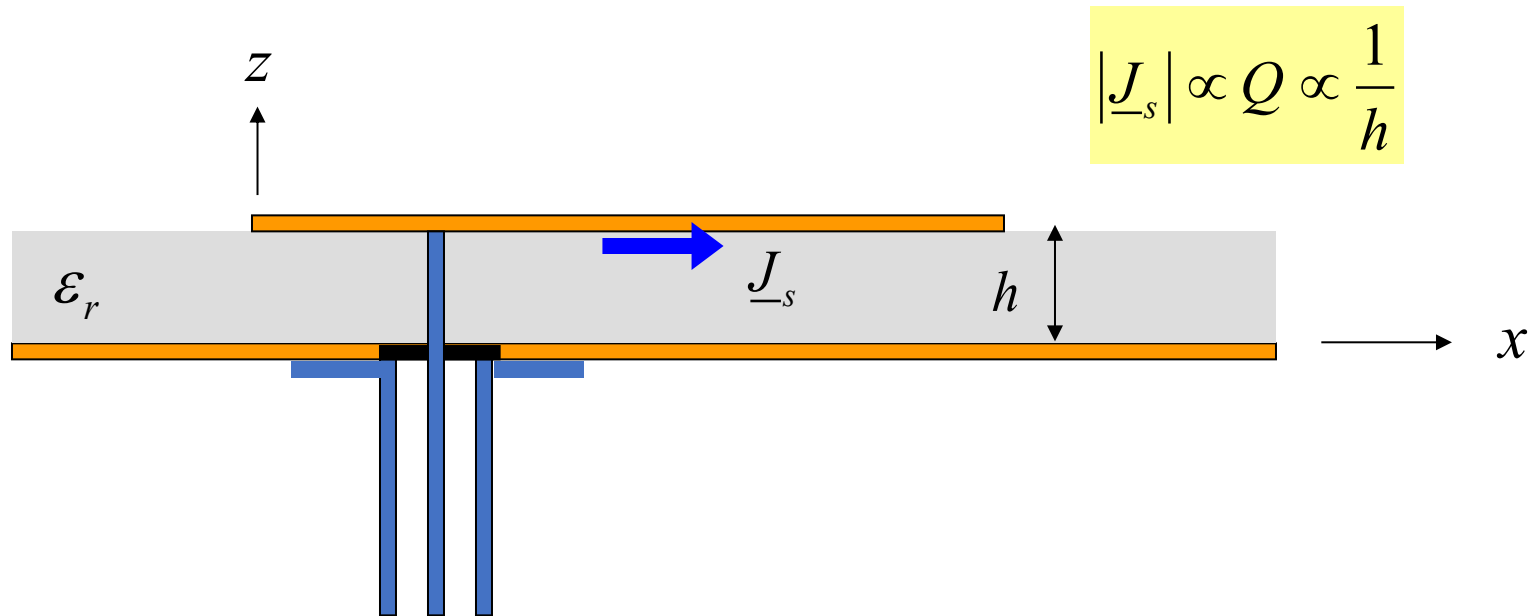

APPLICATIONS OF MICROSTRIP ANTENNAS

1. Mobile phones
2. Satellite communication requires circularly polarised radiation patterns, which can be realised using either square or circular patch microstrip antenna.
3. Global positioning satellite (GPS) systems, circularly polarized microstrip antennae are used.
4. [RFID](#) (radio frequency identification) devices
5. Wearable microstrip antennae are suitable for wireless body area network in telemedicine.

MOBILE PHONE ANTENNAS

1. Mobile phones use different kinds of antennae including:
 - a) Planar inverted-F antenna
 - b) folded inverted conformal antenna mono pole
 - c) whip antenna (original)

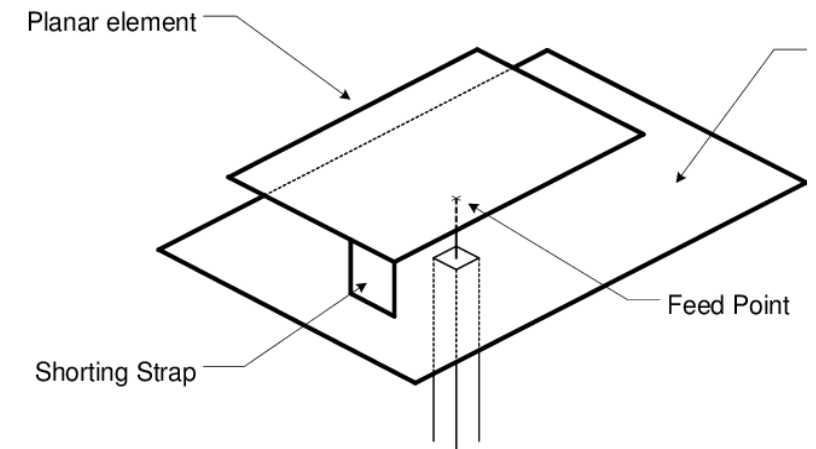
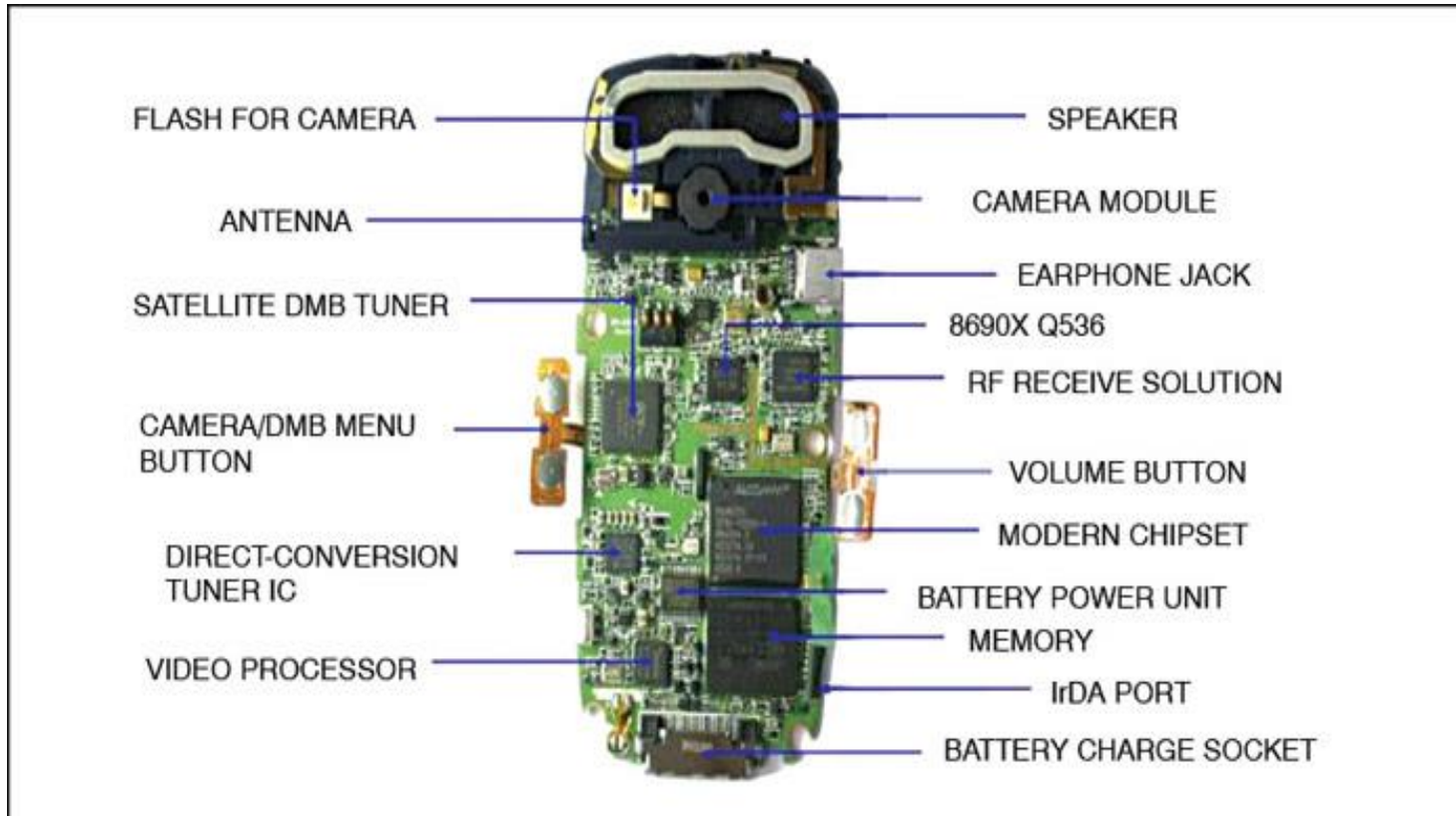

Figure: Planar inverted-F antenna