

BLACK & WHITE TELEVISION

**ECE 516E – ANTENNA & RADIOWAVE
PROPAGATION**

Monday, 17 November 2025

BASIC BLACK & WHITE TELEVISION

1. In the original black and white TV, a single **electron beam** is used to scan a **phosphor screen**.
2. The scan is interlaced, that is, it scans twice per photographed frame.
3. The information is always displayed from left to right. After each line is written, when the beam returns back to the left.
4. the signal is **blanked during retrace**. When the signal reached the bottom it is blanked again until it returns to the top to write the next line

SCAN & RETRACE IN TV SYSTEM

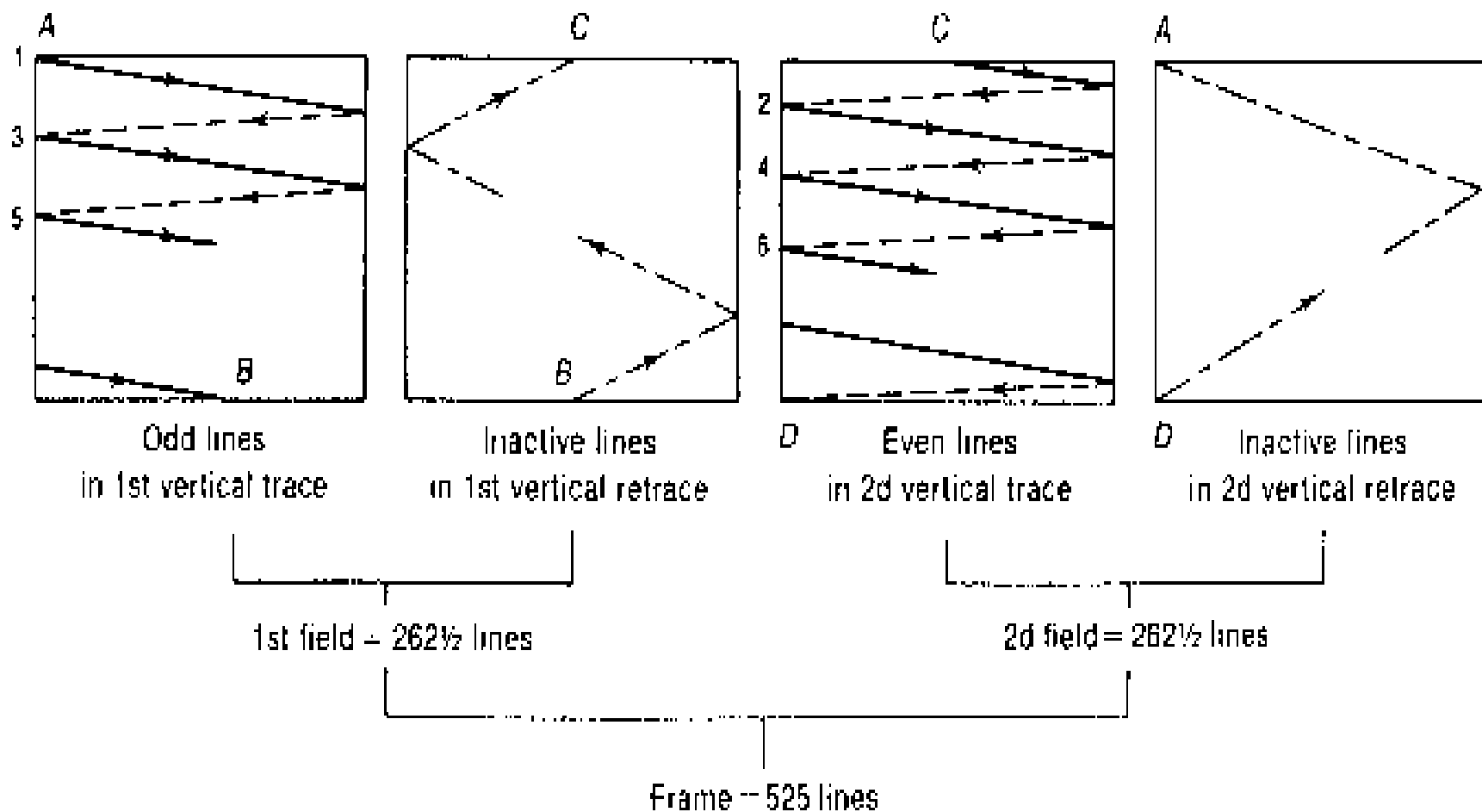

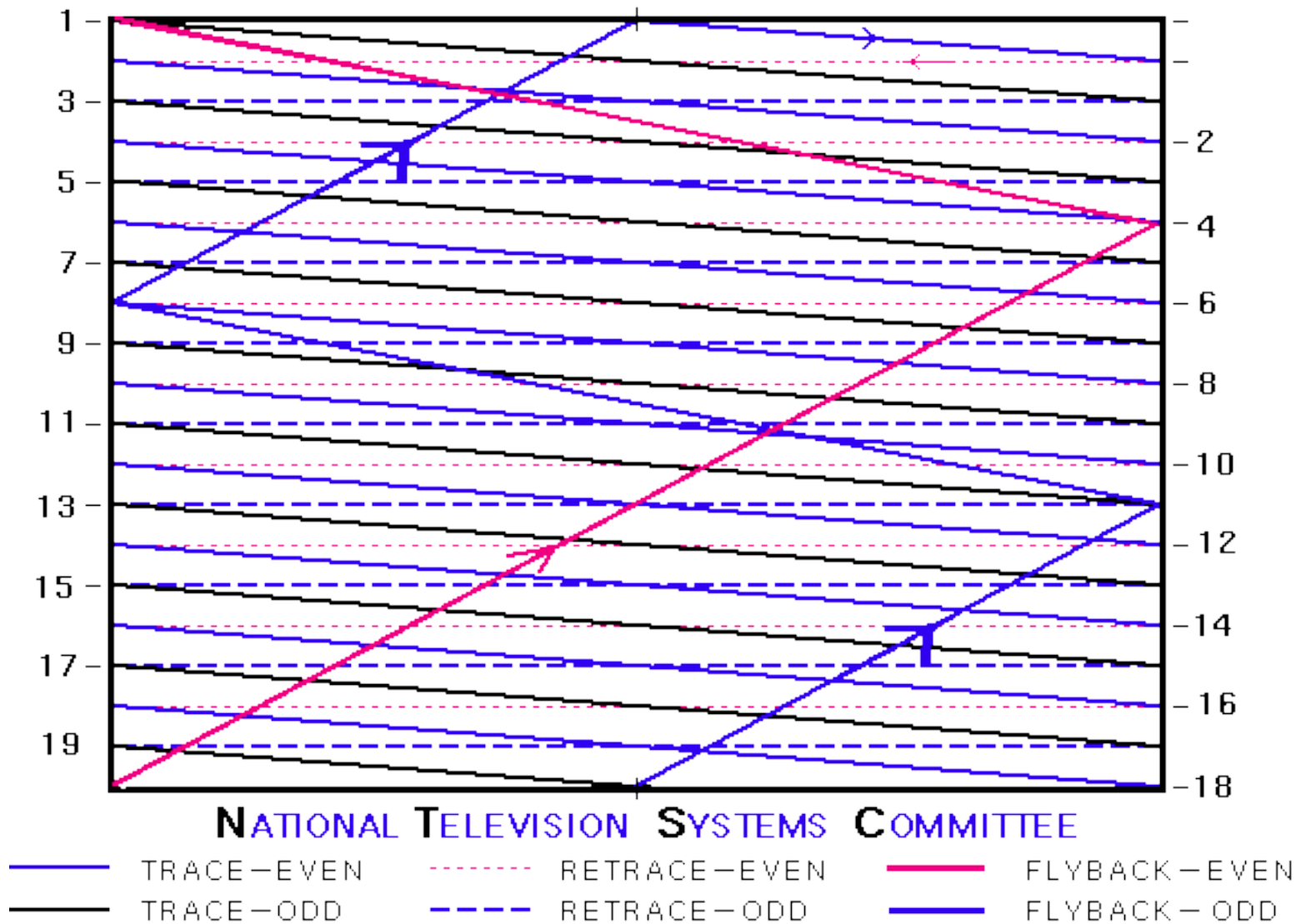

Notice that the beam does not return directly to the top, but zig-zags a bit.

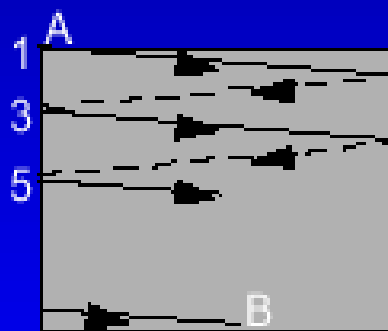
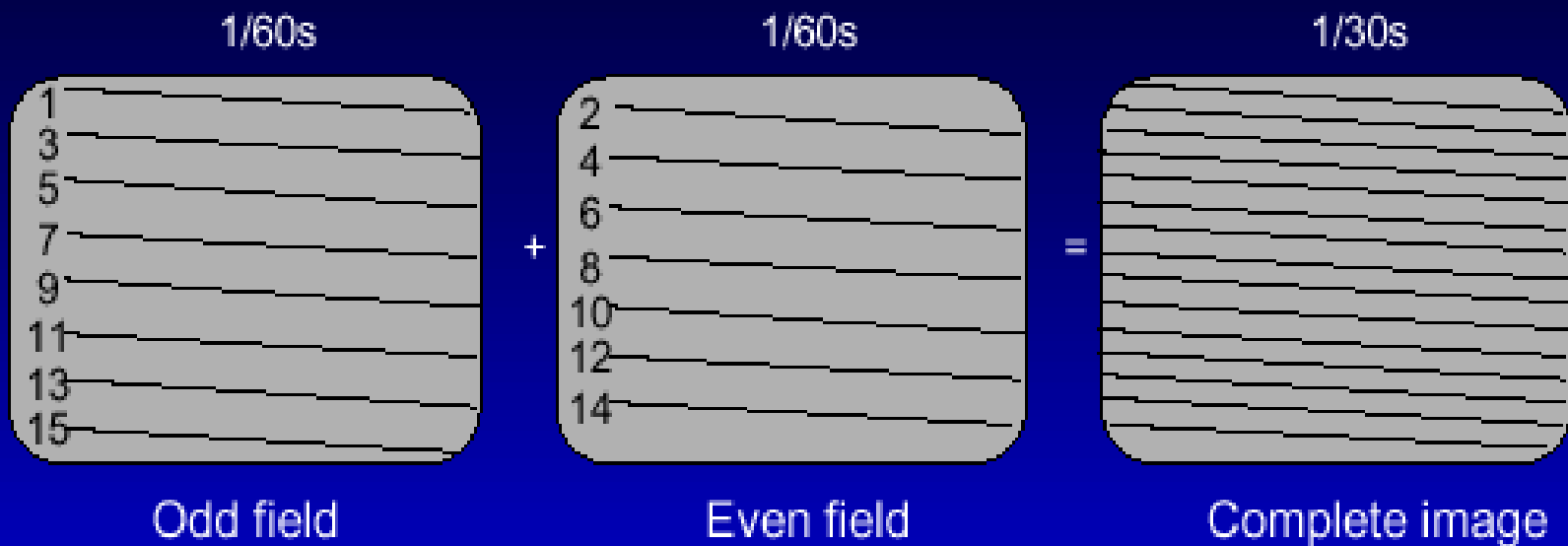

Odd lines

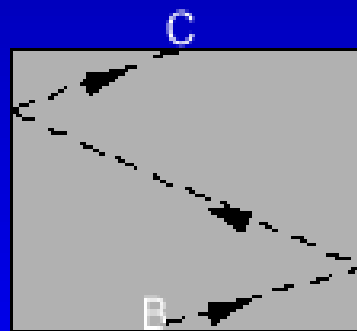

Odd field flyback

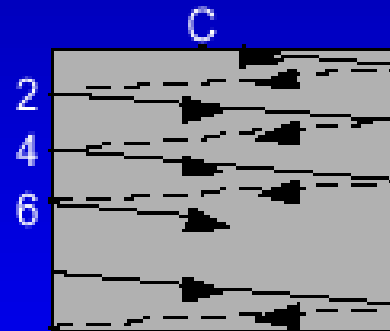

Even lines

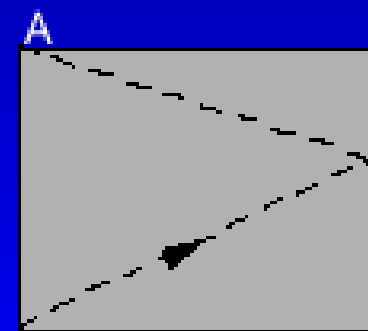

Even field flyback

Number of lines: 525
Number of images: 30

Number of fields: 60
2 fields = 1 image

VERTICAL SCANNING SIGNAL (NTSC)

1. The **vertical scanning signal** for conventional black and white TV is a positive ramp until it is time for the beam to return to the upper left-hand corner.
2. Then it is a negative ramp during the blanked scan lines.

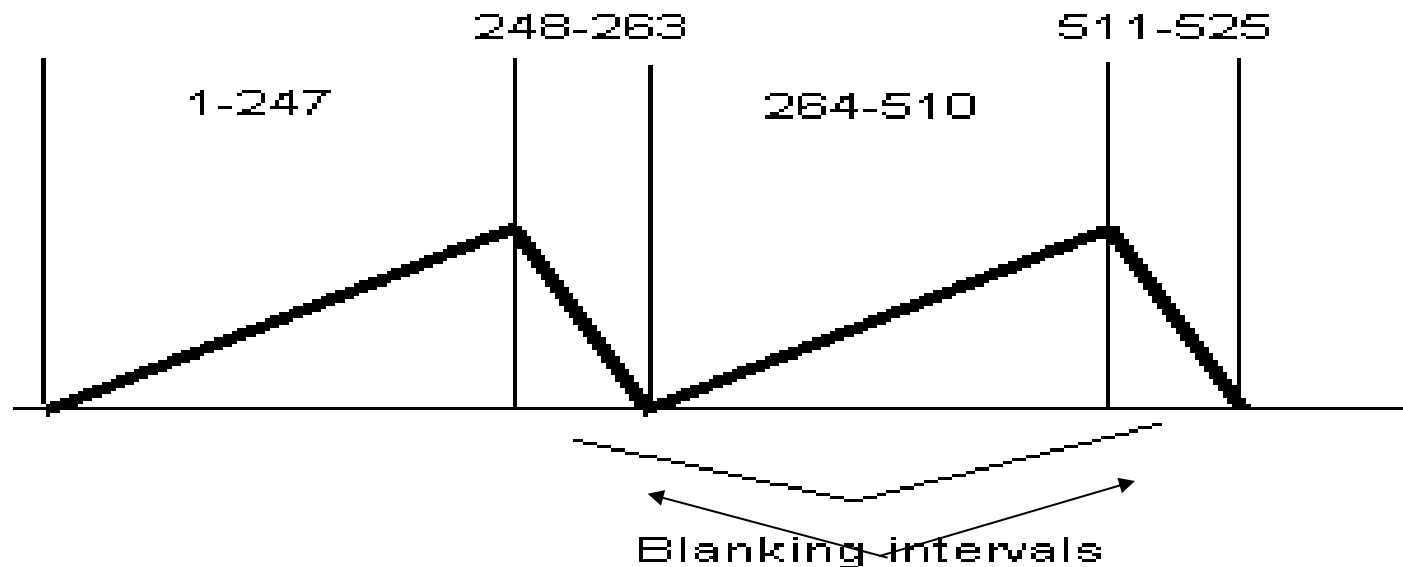

HORIZONTAL SCAN SIGNAL (NTSC)

1. The **horizontal scan signal** is very much the same as vertical.

2. The horizontal scan rate is 525×29.97 or 15,734 Hz.

Therefore, $\frac{1}{15734} = 63.6 \mu\text{S}$ are allocated per line.

3. Typically, about $10 \mu\text{S}$ of this is devoted to the blanking line on the horizontal scan leaving $63.6 - 10 = 53.6 \mu\text{S}$.

4. There are 427 pixels per horizontal scan line and so each pixel is scanned for $\frac{53.6 \times 10^{-6}}{427} \approx 125 \text{ ns}$.

BW SCAN SIGNAL

- The electron beam is analog modulated across the horizontal line. The modulation then translates into intensity changes in electron beam and thus gray scale levels on the picture screen

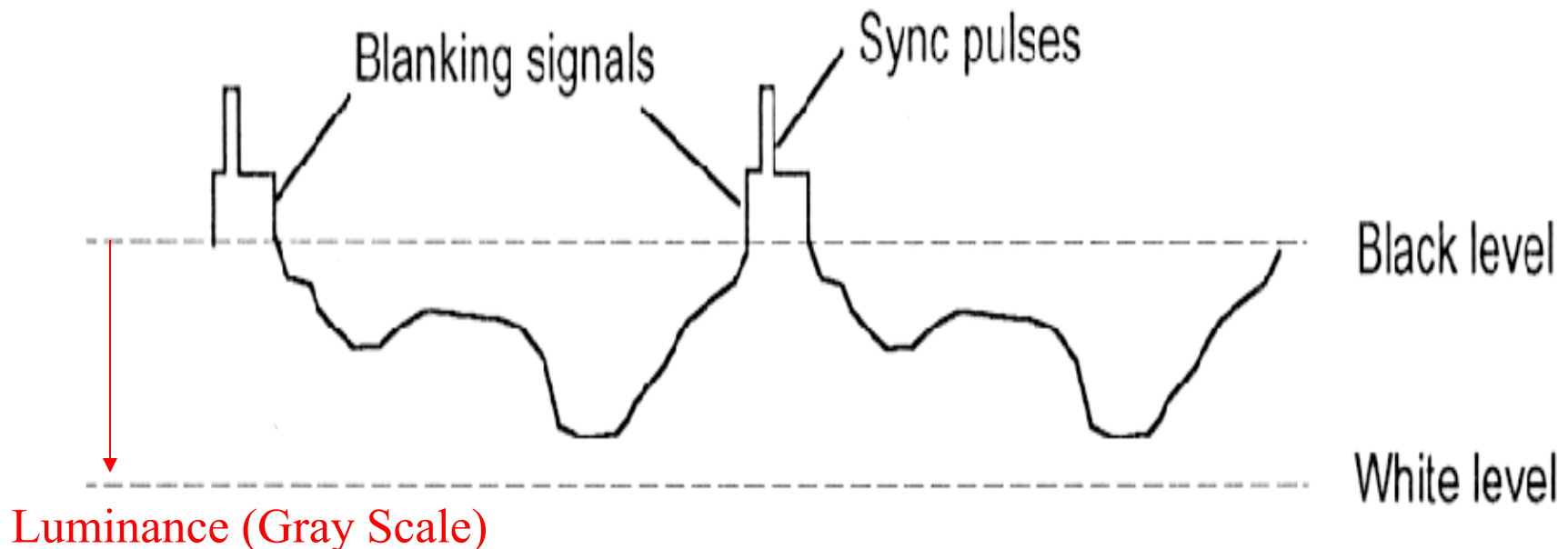

HORIZONTAL BLANKING & SYNC PULSES

- Horizontal blanking signal and synchronization pulse is quite well defined.
- For black and white TV, the "front porch" is 0.02 times the distance between pulses, and the "back porch" is 0.06 times the distance between pulses.

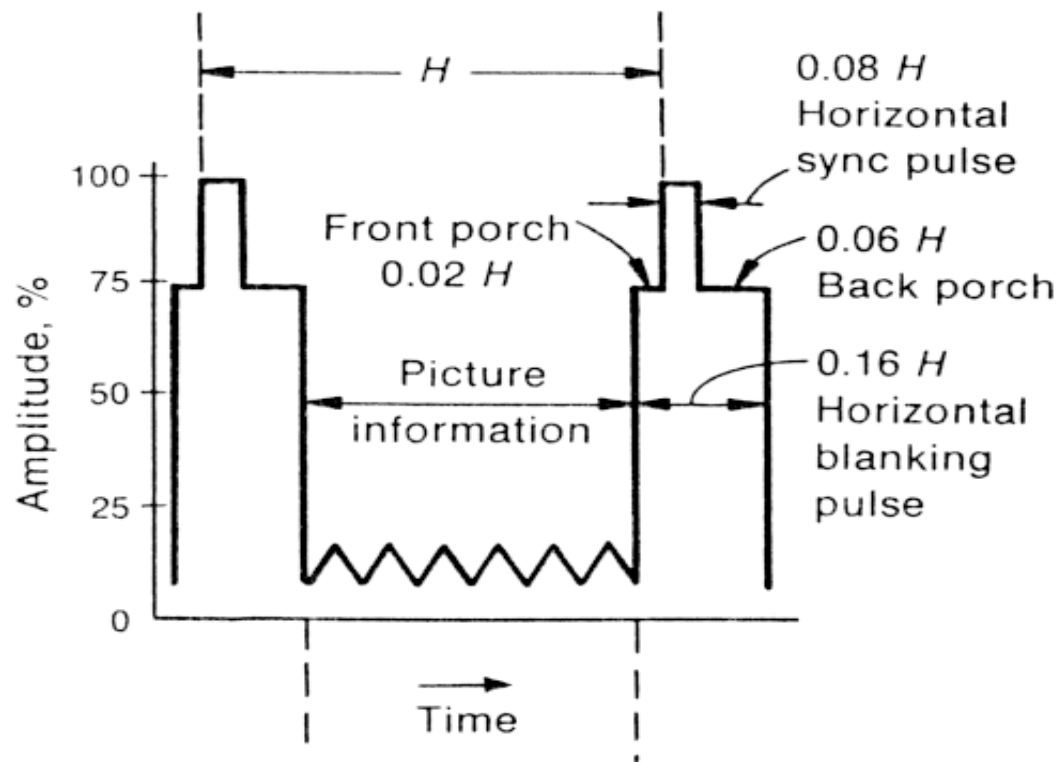

SAWTOOTH WAVEFORMS

The **synchronization signals** are used to generate the sawtooth waveforms that drive both horizontal and vertical retrace.

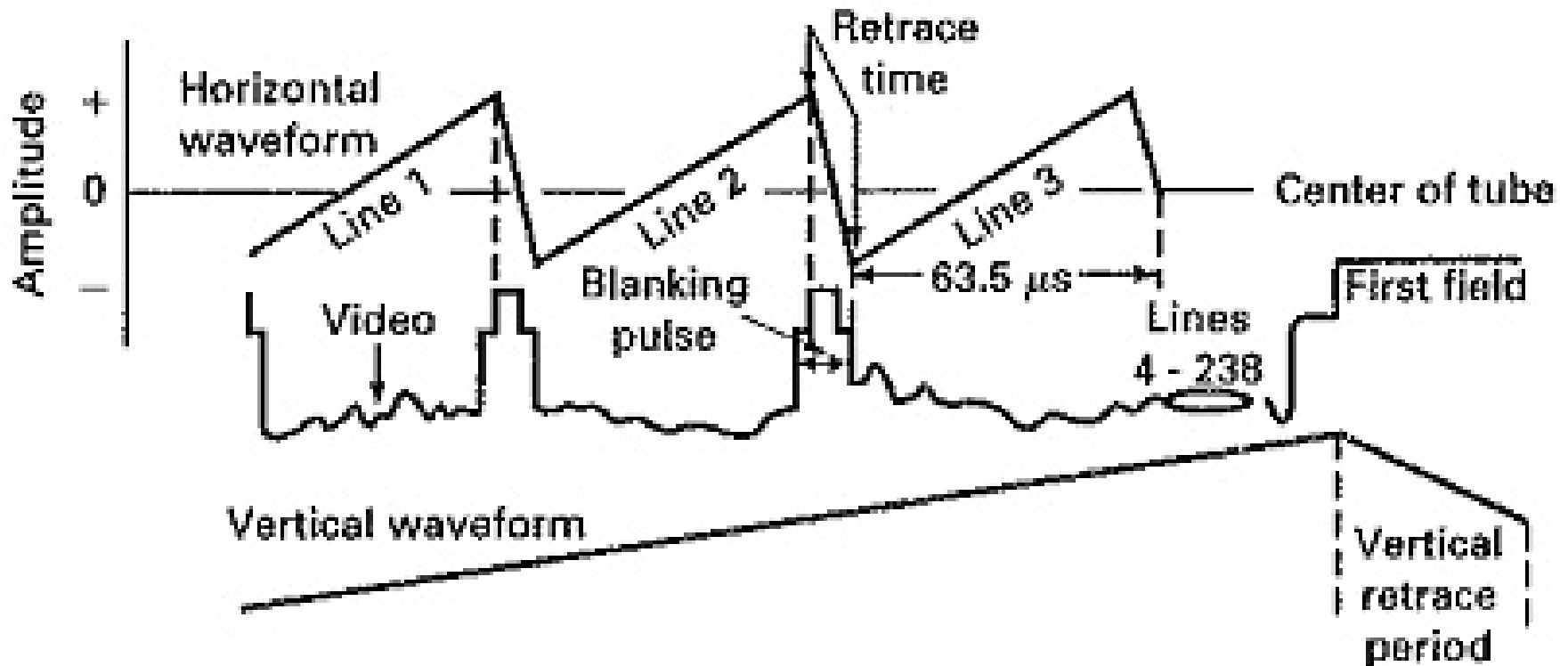

TELEVISION BANDWIDTH

1. The television bandwidth is 6 MHz.
2. The sub-carrier for the colour is 3.58 MHz (NTSC) off the carrier for the monochrome information.
3. The sound carrier is 4.5 MHz off the carrier for the monochrome information.
4. There is a gap of 1.25 MHz on the low end and 0.25 MHz on the high end to avoid cross talk with other channels when TV signals are multiplexed.

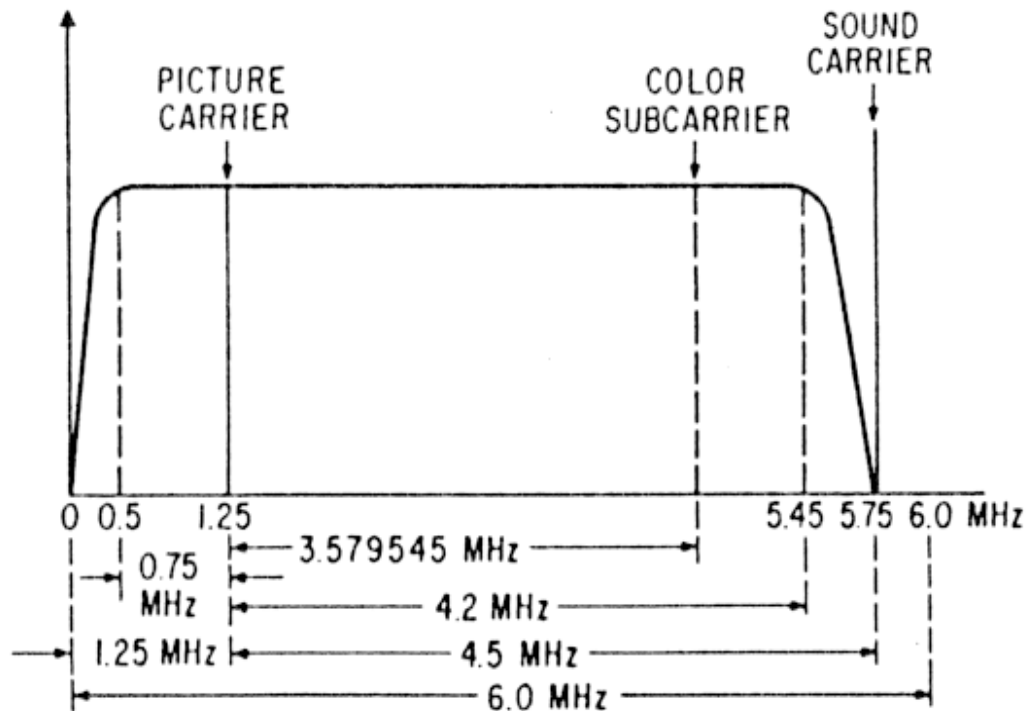

MONOCHROME TELEVISION TRANSMITTER

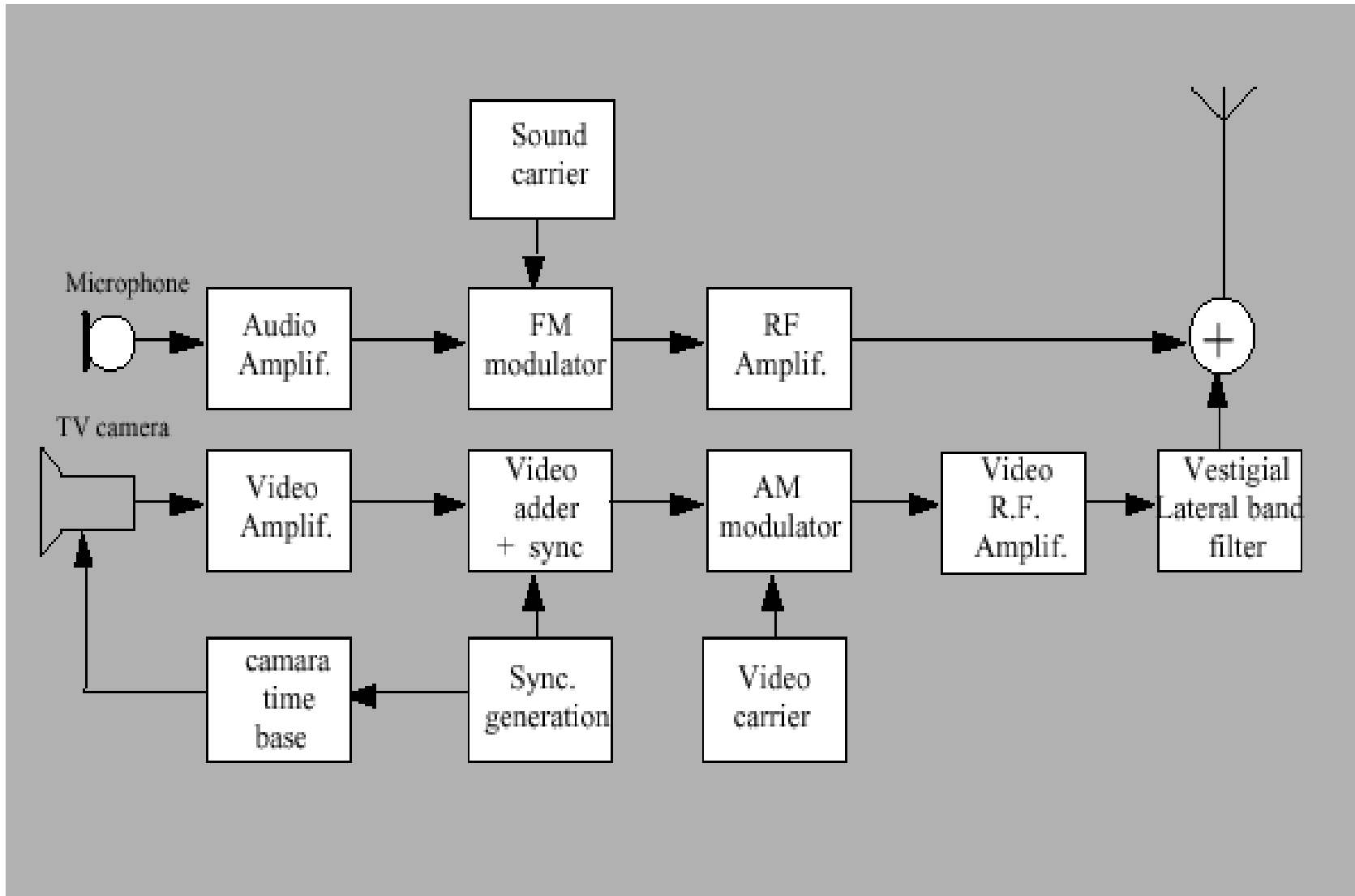

MONOCHROME TELEVISION RECEIVER

