

## ECE 516E – ANTENNA & RADIOWAVE PROPAGATION

### EARLY TELEVISION SYSTEMS - STUDY GUIDE

#### 1.OBJECTIVE

This study guide provides undergraduate electrical engineering students with a structured overview of key television technology concepts, from early historical developments to fundamental technical principles.

#### 2. EARLY TELEVISION SYSTEMS

##### 2.1 Mechanical Television Systems

Early television systems relied on mechanical scanning devices to capture and display images.

##### 2.1.1 Nipkow Disk

Invented by Paul Nipkow in 1884, this spinning disk with a spiral pattern of holes was the first practical mechanical television scanning device. Each hole scanned one line of the image as the disk rotated.

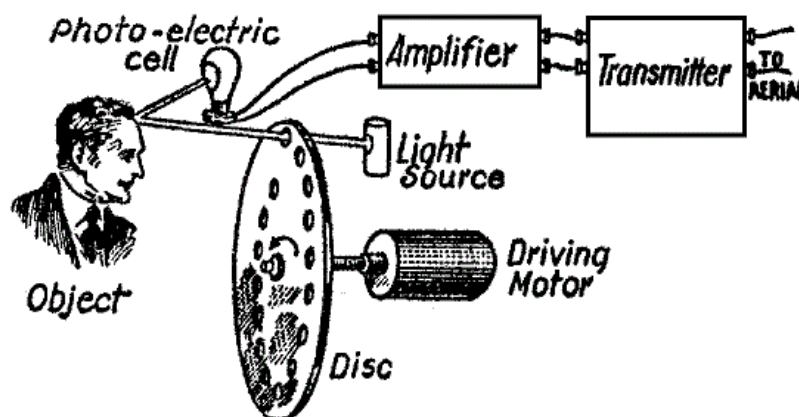

FIG. 1.—Nipkow Disc Scanning at Televisor or Transmitter.  
[www.hawestv.com](http://www.hawestv.com)

##### 2.1.2 John Logie Baird's System

Using a Nipkow disk, Baird gave the first public demonstration of televised silhouette images in motion in 1925 at Selfridges department store in London. By 1926, he demonstrated transmission of real human faces.

##### 2.1.3 Limitations

Mechanical systems suffered from flickering images due to low scan rates and poor resolution from the relatively large size of scanning holes. They could not match the dictates of human vision such as the thresholds set by the persistence of vision and critical frequency.

#### 2.2 Transition to Electronic Television

The limitations of mechanical systems prompted development of fully electronic television.

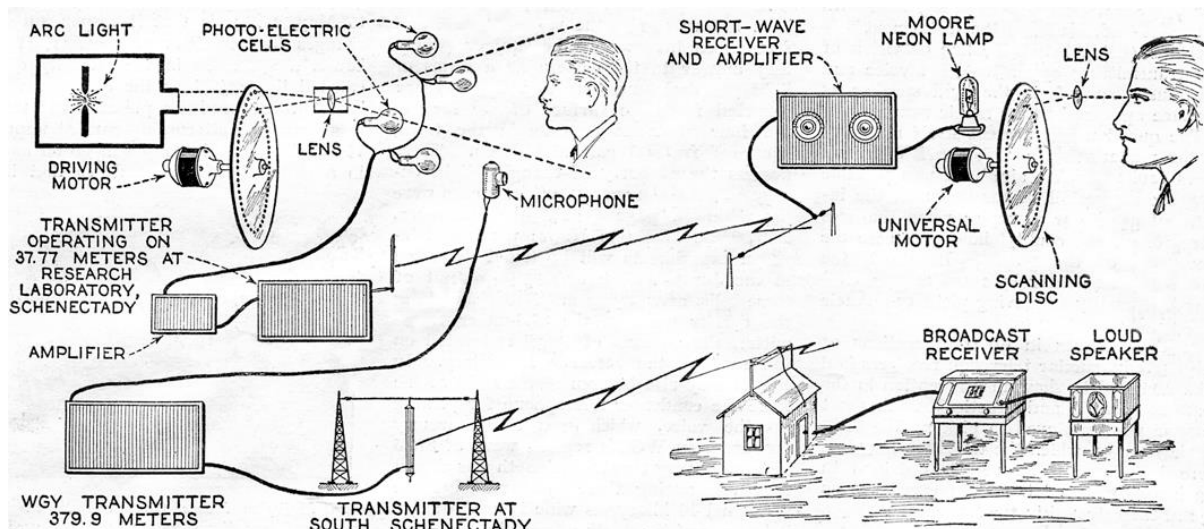

**FIG.2** Transmission and Reception of Mechanical Television Signals

### 2.2.1 Cathode Ray Tube (CRT)

A.A. Campbell Swinton first proposed using cathode rays (electron beams) for television in 1908, suggesting they could “paint” fleeting pictures on phosphorescent screens without the flicker problems of mechanical systems.

### 2.2.2 Key Inventors

**Boris Rosing and Vladimir Zworykin:** In 1911, they created a system using a mechanical scanner with a CRT receiver.

**Philo Farnsworth:** Demonstrated the first fully electronic television system with his Image Dissector camera tube in 1927.

**Vladimir Zworykin:** Developed the Iconoscope camera tube for RCA in the early 1930s, which produced acceptable pictures with reasonable light levels.

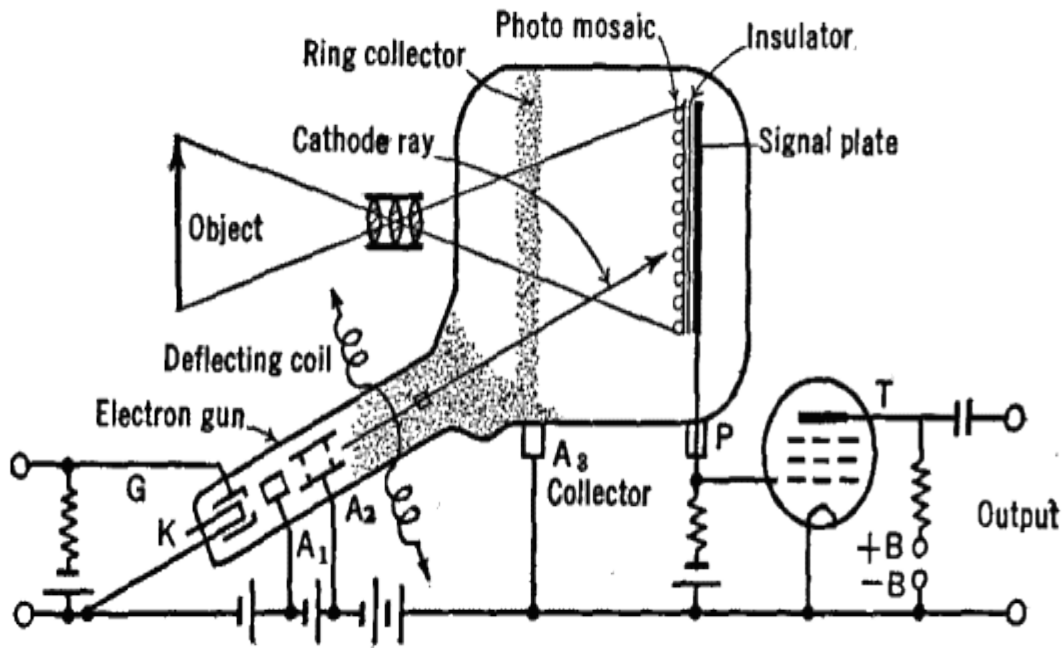

FIG.3 The original Iconoscope camera

### 2.3 Early Broadcasting Systems

| System   | Lines | Frame Rate | Region          | Year Introduced |
|----------|-------|------------|-----------------|-----------------|
| System A | 405   | 25 fps     | United Kingdom  | 1936            |
| System B | 625   | 25 fps     | Western Europe  | 1950            |
| System M | 525   | 30 fps     | Americas, Japan | 1941            |
| System E | 819   | 25 fps     | France          | 1949            |

The first scheduled electronic television broadcasting began in England in 1936, with the BBC alternating between Baird's 240-line mechanical system and EMI's 405-line electronic system before adopting the superior electronic system.

## 3. TELEVISION SIGNAL TRANSMISSION AND RECEPTION

### 3.1 Signal Generation and Composition

Television signals combine visual information with synchronization data.

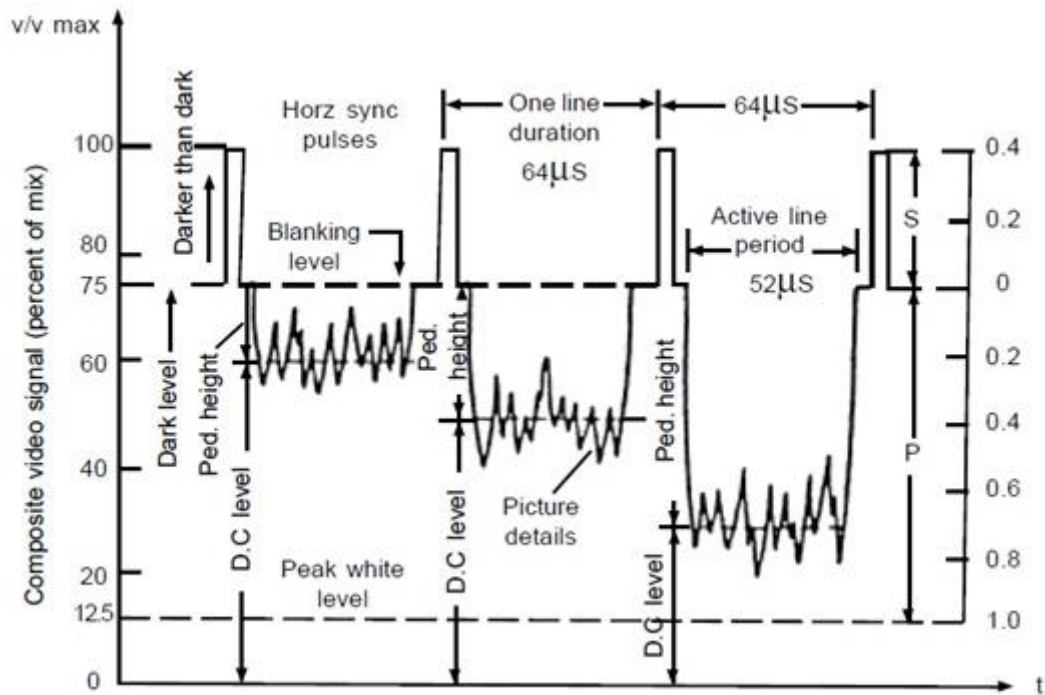

**FIG.4** Composite video signal

### 3.1.1. Composite Video Signal:

Contains picture information, synchronization pulses, and blanking pulses.

### 3.1.2 Colour Television Signals

Consist of two components:

- **Luminance (Y):** Black-and-white brightness information.
- **Chrominance:** Colour information containing hue and saturation data.

## 3.2 Transmission Methods

### 3.2.1 Carrier Signals

Television signals are shifted to Very High Frequency (VHF) or Ultra High Frequency (UHF) channels for broadcast.

### 3.2.2 Modulation

- **Picture:** Amplitude modulation (AM) of the visual carrier.
- **Sound:** Frequency modulation (FM) transmitted on a separate carrier, typically 4.5 MHz above the picture carrier in NTSC systems.

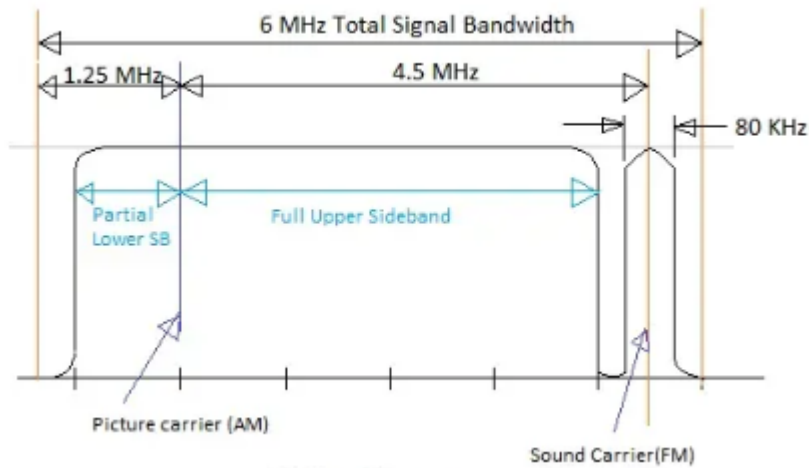

**FIG.5** Spectrum of Monochrome Television Signal (NTSC)

### 3.2.3 Transmission Paths

Signals can be distributed via terrestrial radio signals, coaxial cable, satellite microwave, or internet protocols.

### 3.3 Reception and Display

Television receivers reverse the transmission process:

1. Separate incoming signals into visual and audio components
2. Demodulate both signals back to their original frequencies
3. Apply processed signals to the display and loudspeaker

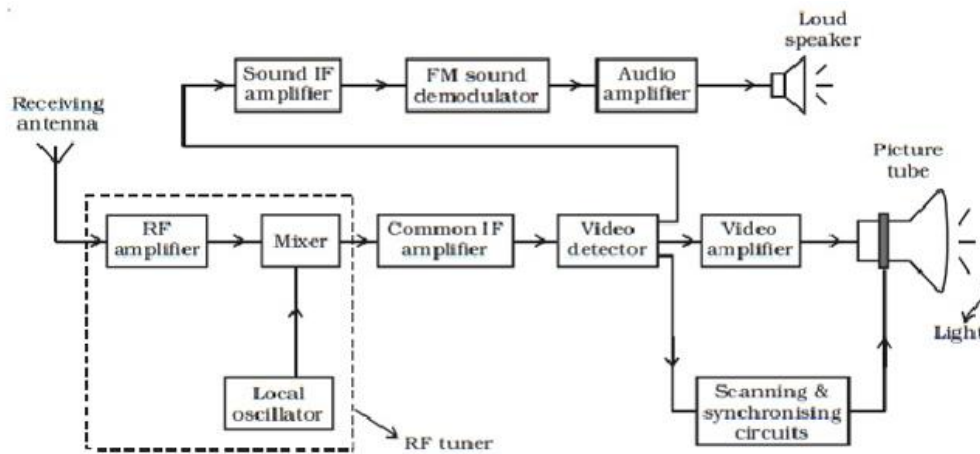

**FIG.6** Monochrome (Black and White) Television Receiver

## 4. ASPECT RATIO OF TELEVISION DISPLAYS

Aspect ratio defines the proportional relationship between an image's width and height.

### 4.1 Common Aspect Ratios

| Aspect Ratio  | Common Name | Primary Usage                      |
|---------------|-------------|------------------------------------|
| 4:3 (1.33:1)  | Standard    | Early television, classic monitors |
| 16:9 (1.78:1) | Widescreen  | HDTV, modern digital television    |
| 21:9          | Ultrawide   | Gaming, specialty monitors         |

### 4.2 Historical Development

The 4:3 aspect ratio was adopted as the television standard in the 1930s, matching the Academy ratio (1.375:1) used in motion pictures after the advent of sound films.

Widescreen 16:9 format emerged in response to widescreen cinema formats developed in the 1950s to compete with television.

#### 4.2.1 Critical Consideration

Display quality is optimized when the aspect ratio of the monitor matches the aspect ratio of the video source. Mismatched ratios result in distorted images, pillarboxing (vertical black bars), or chopped images.

## 5. PHOTOMETRIC UNITS

Photometry measures electromagnetic radiation (light) as perceived by the human eye, weighted by the eye's sensitivity function.

### 5.1 Key Photometric Quantities

| Quantity           | Symbol | Unit                    | Definition                          | Radiometric Equivalent               |
|--------------------|--------|-------------------------|-------------------------------------|--------------------------------------|
| Luminous Flux      | $\Phi$ | Lumen (lm)              | Total perceived power of light      | Radiant Flux (W)                     |
| Luminous Intensity | I      | Candela (cd)            | Luminous flux per solid angle       | Radiant Intensity (W/sr)             |
| Luminance          | L      | cd/m <sup>2</sup> (nit) | Luminous intensity per unit area    | Radiance (W/sr/m <sup>2</sup> )      |
| Illuminance        | E      | Lux (lx)                | Luminous flux incident on a surface | Irradiance (W/m <sup>2</sup> )       |
| Luminous Exposure  | H      | lx·s                    | Accumulated illuminance over time   | Radiant Exposure (J/m <sup>2</sup> ) |

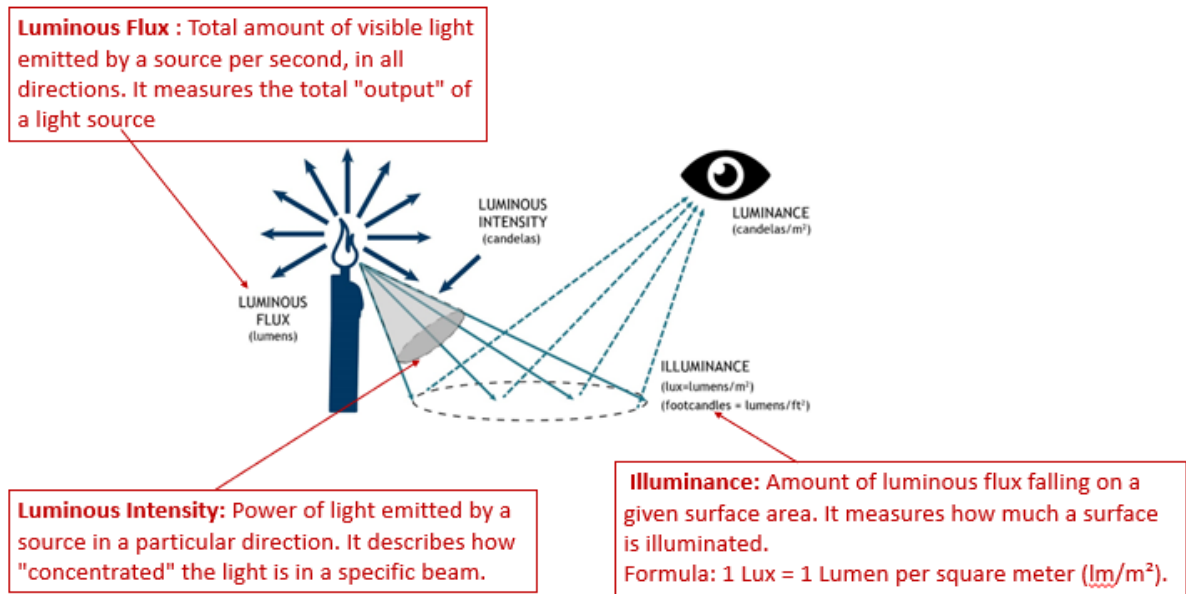

FIG.7 Photometric units

## 5.2 Importance of Photometric Units in Television

Photometric measurements are essential for:

- Standardizing display brightness and contrast
- Calibrating cameras and displays for consistent colour reproduction
- Designing television studios with proper lighting conditions
- Ensuring viewing comfort in various ambient light conditions

## 6. PHOTOCONDUCTIVITY

Photoconductivity is an optical and electrical phenomenon where a material becomes more electrically conductive when exposed to electromagnetic radiation.

### 6.1 Fundamental Principles

#### 6.1.1 Basic Mechanism

When light with sufficient energy strikes a semiconductor, electrons are excited across the band gap, increasing the number of charge carriers (electrons and holes) and thus enhancing electrical conductivity.

#### 6.1.2 Circuit Implementation

When a photoconductive material is connected in series with a bias voltage and load resistor, changes in light intensity vary the material's conductivity, changing current flow and creating a measurable voltage drop across the load resistor.

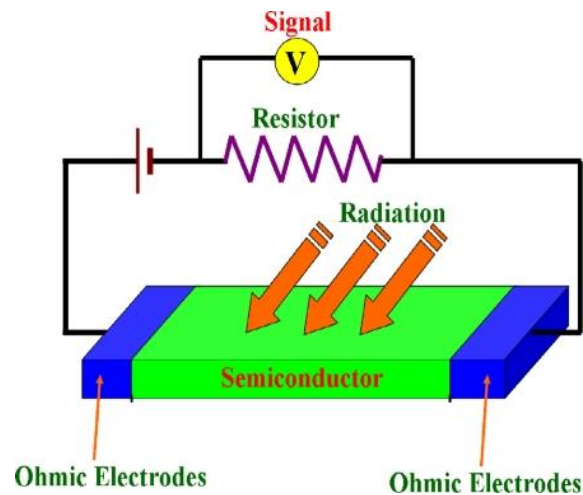

**FIG.8** Principle of photoconductivity

## 6.2 Television Technology

### 6.2.1 Early Television Cameras

Selenium photocells were used in early mechanical television systems to convert light patterns into electrical signals.

### 6.2.2 Modern Image Sensors

Photoconductive principles form the basis for CCD and CMOS image sensors in modern cameras.

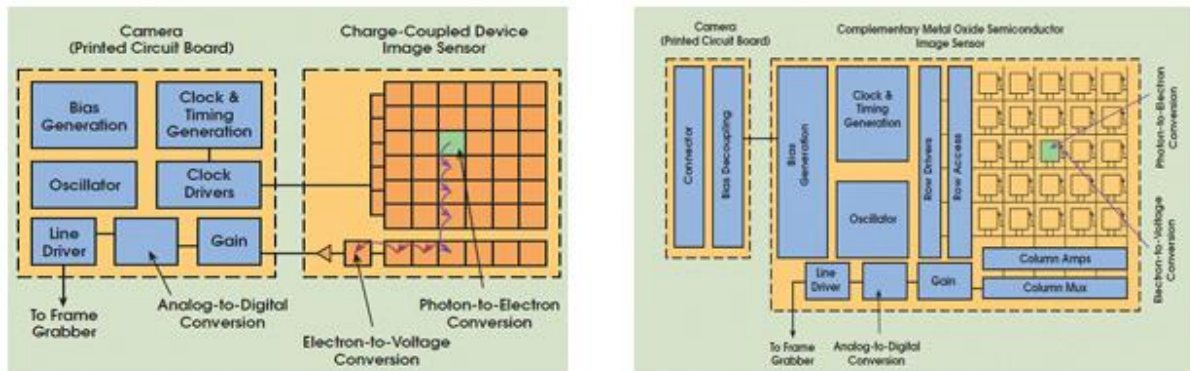

**FIG. 9.** CCD and CMOS image sensors

### 6.2.3 Photoresistors

Used in various television system components for light detection and measurement.

## 6.3 Specialized Photoconductivity Phenomena

### 6.3.1 Negative Photoconductivity

Some materials exhibit reduced conductivity when illuminated, observed in hydrogenated amorphous silicon (used in some display technologies), ZnO nanowires, and graphene.

### 6.3.2 Sensitization

Engineering technique that amplifies photoconductive response by doping materials to create recombination centres with longer carrier lifetimes, increasing photoconductive gain.

### **6.3.3 Photocurrent Spectroscopy**

Characterization technique used to study optoelectronic properties of semiconductors by measuring current generated in response to light of varying wavelengths.

## **7. STUDY RECOMMENDATIONS**

For comprehensive understanding, electrical engineering students should:

1. **Compare and contrast** mechanical vs. electronic scanning systems
2. **Diagram and analyse** television signal transmission chains from camera to display
3. **Calculate** aspect ratio conversions and understand their visual implications
4. **Apply** photometric principles to display design and viewing environment analysis
5. **Design simple circuits** utilizing photoconductive elements for light sensing